

The
United
States
of
America



**The Director of the United States
Patent and Trademark Office**

Has received an application for a patent for a new and useful invention. The title and description of the invention are enclosed. The requirements of law have been complied with, and it has been determined that a patent on the invention shall be granted under the law.

Therefore, this

United States Patent

Grants to the person(s) having title to this patent the right to exclude others from making, using, offering for sale, or selling the invention throughout the United States of America or importing the invention into the United States of America, and if the invention is a process, of the right to exclude others from using, offering for sale or selling throughout the United States of America, or importing into the United States of America, products made by that process, for the term set forth in 35 U.S.C. 154(a)(2) or (c)(1), subject to the payment of maintenance fees as provided by 35 U.S.C. 41(b). See the Maintenance Fee Notice on the inside of the cover.

Michelle K. Lee

Deputy Director of the United States Patent and Trademark Office



US008938535B2

(12) **United States Patent**
Lin et al.

(10) **Patent No.:** **US 8,938,535 B2**
(45) **Date of Patent:** **Jan. 20, 2015**

(54) **SYSTEM FOR REAL TRAFFIC REPLAY OVER WIRELESS NETWORKS**

(75) Inventors: **Ying-Dar Lin**, Hsinchu (TW); **Chia-Yu Ku**, Hsinchu (TW); **Pei-Hsuan Li**, Hsinchu (TW); **Yuan-Cheng Lai**, Hsinchu (TW)

(73) Assignee: **National Chiao Tung University**, Hsinchu (TW)

(*) Notice: Subject to any disclaimer, the term of this patent is extended or adjusted under 35 U.S.C. 154(b) by 246 days.

8,135,339	B2 *	3/2012	Ranson et al.	455/24
8,484,002	B2 *	7/2013	Yang et al.	703/8
8,505,098	B2 *	8/2013	Lin et al.	726/24
8,578,493	B1 *	11/2013	Cowan et al.	726/23
8,607,229	B2 *	12/2013	Malloy et al.	718/1
2002/0066082	A1 *	5/2002	Araya et al.	717/135
2002/0198694	A1 *	12/2002	Yang et al.	703/6
2003/0083847	A1 *	5/2003	Schertz et al.	702/186
2003/0084318	A1 *	5/2003	Schertz	713/200
2003/0084340	A1 *	5/2003	Schertz et al.	713/201
2006/0209866	A1	9/2006	Steenkiste et al.	
2006/0227796	A1 *	10/2006	Wei et al.	370/412
2007/0093997	A1 *	4/2007	Yang et al.	703/8
2008/0120081	A1 *	5/2008	Chandrashekar et al.	703/13
2010/0167639	A1 *	7/2010	Ranson et al.	455/24
2010/0292971	A1 *	11/2010	Sachse	703/6
2012/0005754	A1 *	1/2012	Lin et al.	726/24

(21) Appl. No.: **13/486,556**

(22) Filed: **Jun. 1, 2012**

(65) **Prior Publication Data**

US 2013/0326052 A1 Dec. 5, 2013

(51) **Int. Cl.**
G06F 15/173 (2006.01)

(52) **U.S. Cl.**
USPC **709/224**; 709/223; 709/225

(58) **Field of Classification Search**
USPC 709/223, 224, 238, 201-203, 232; 370/394, 252

See application file for complete search history.

(56) **References Cited**

U.S. PATENT DOCUMENTS

6,384,739	B1	5/2002	Roberts, Jr.	
6,507,604	B1	1/2003	Kuo	
7,203,173	B2	4/2007	Bonney et al.	
7,349,670	B2	3/2008	Mlinarsky et al.	
7,366,647	B2 *	4/2008	Araya et al.	703/14
7,890,821	B2	2/2011	Music et al.	
7,921,333	B2	4/2011	Smith et al.	
7,953,092	B2	5/2011	Pepper et al.	
7,965,726	B2 *	6/2011	Wei et al.	370/412
7,970,407	B2 *	6/2011	Vincent	455/446

OTHER PUBLICATIONS

Li et al., "Real Traffic Replay over WLAN with Environment Emulation", A Thesis Submitted to Institute of Computer Science and Engineering, College of Computer Science, National Chiao Tung University, pp. 1-26 (Published Jun. 3, 2011).

* cited by examiner

Primary Examiner — Sargon Nano

(74) *Attorney, Agent, or Firm* — Edwards Wildman Palmer LLP; Peter F. Corless; Steven M. Jensen

(57) **ABSTRACT**

A real traffic replay over wireless networks with environment emulation and an event-driven automata-synchronized replay method are disclosed. The system includes a first traffic capture module configured to capture packet traces and environment effects in a real environment, a first event transform module configured to transform the packet traces into a sequence of events, and a reproduce module configured to receive the environment effects from the first traffic capture module and the sequence of events from the first event transform module such as to control a replay of the environment effects in the real environment and the sequence of events coordinately by means of automata.

17 Claims, 9 Drawing Sheets

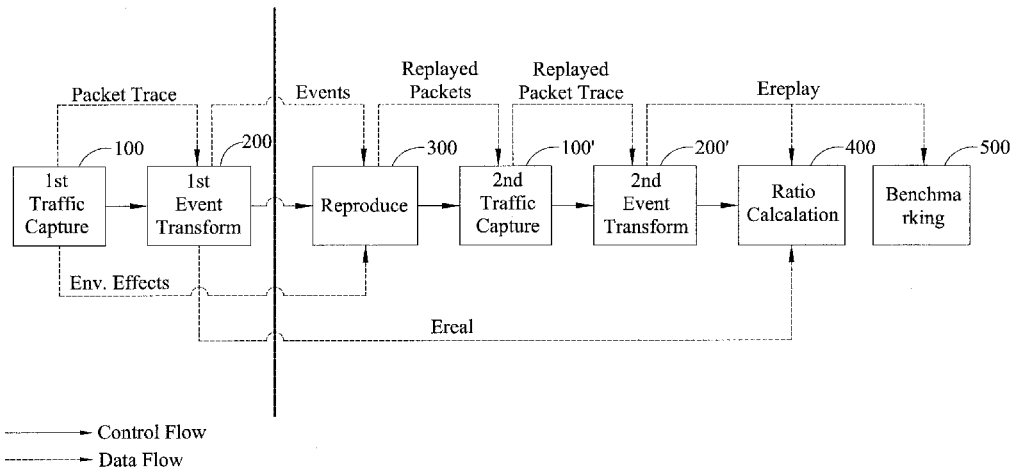

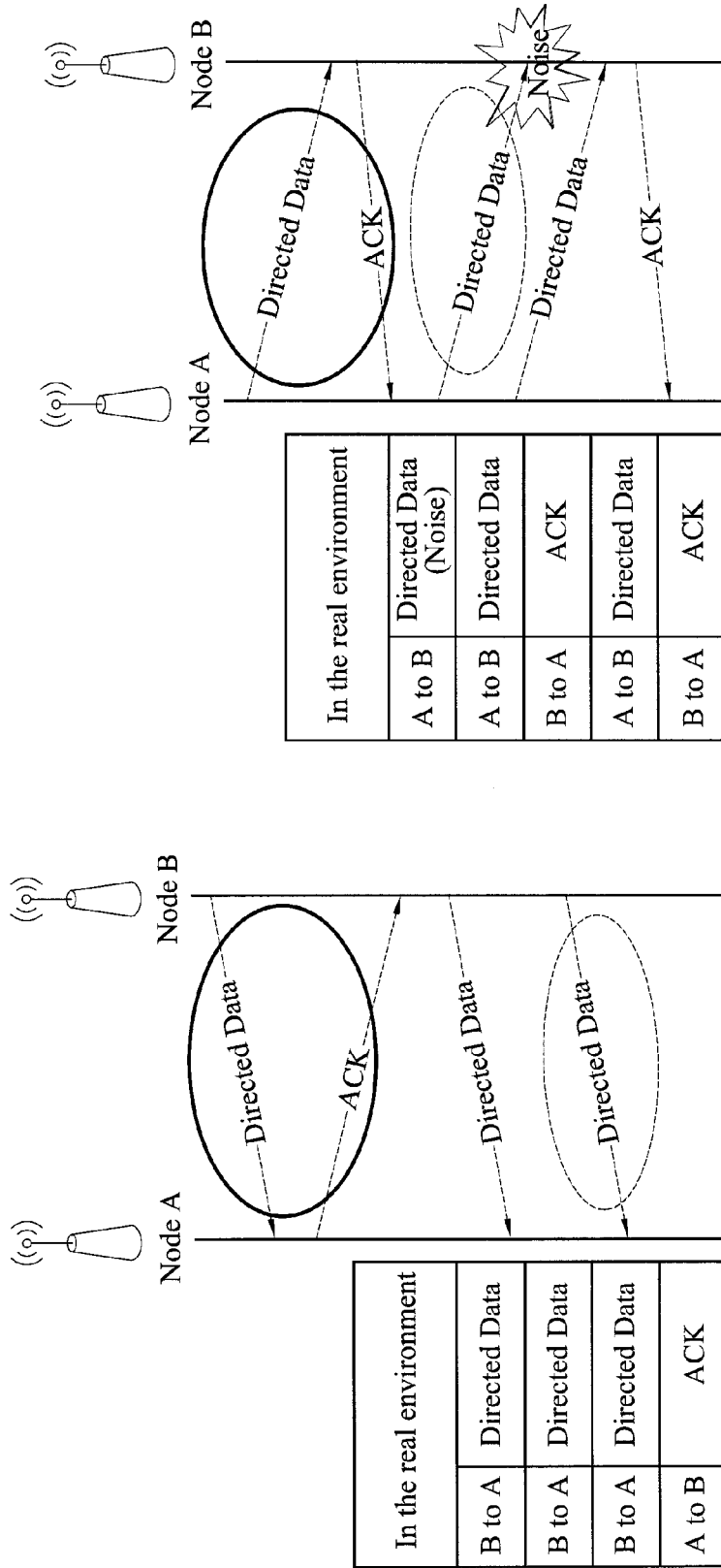

(a) Lack of packet replay control

(b) Lack of environment emulation

FIG. 1A

FIG. 1B

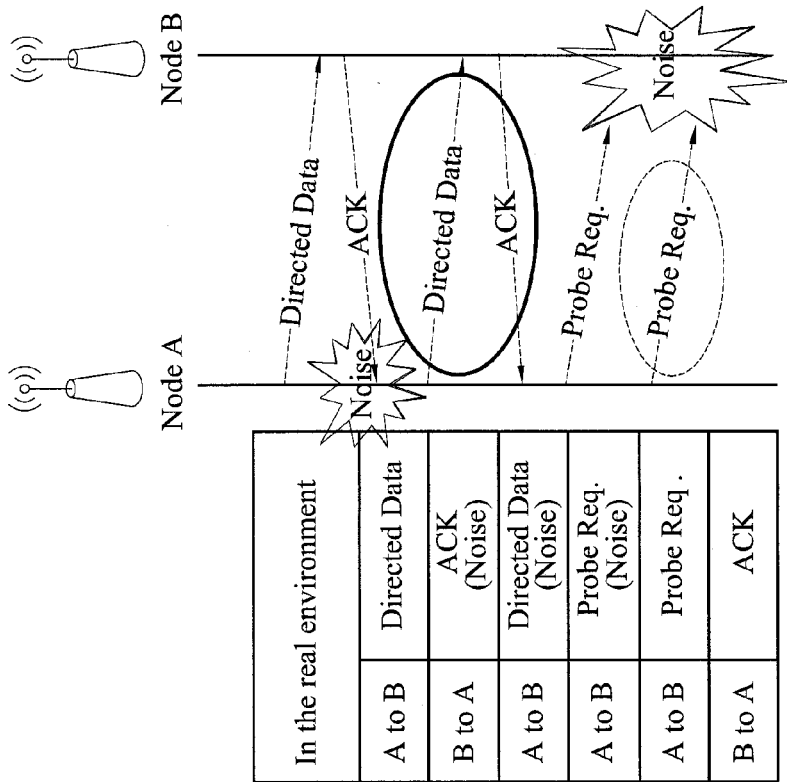

(c) Poor coordination

FIG.1C

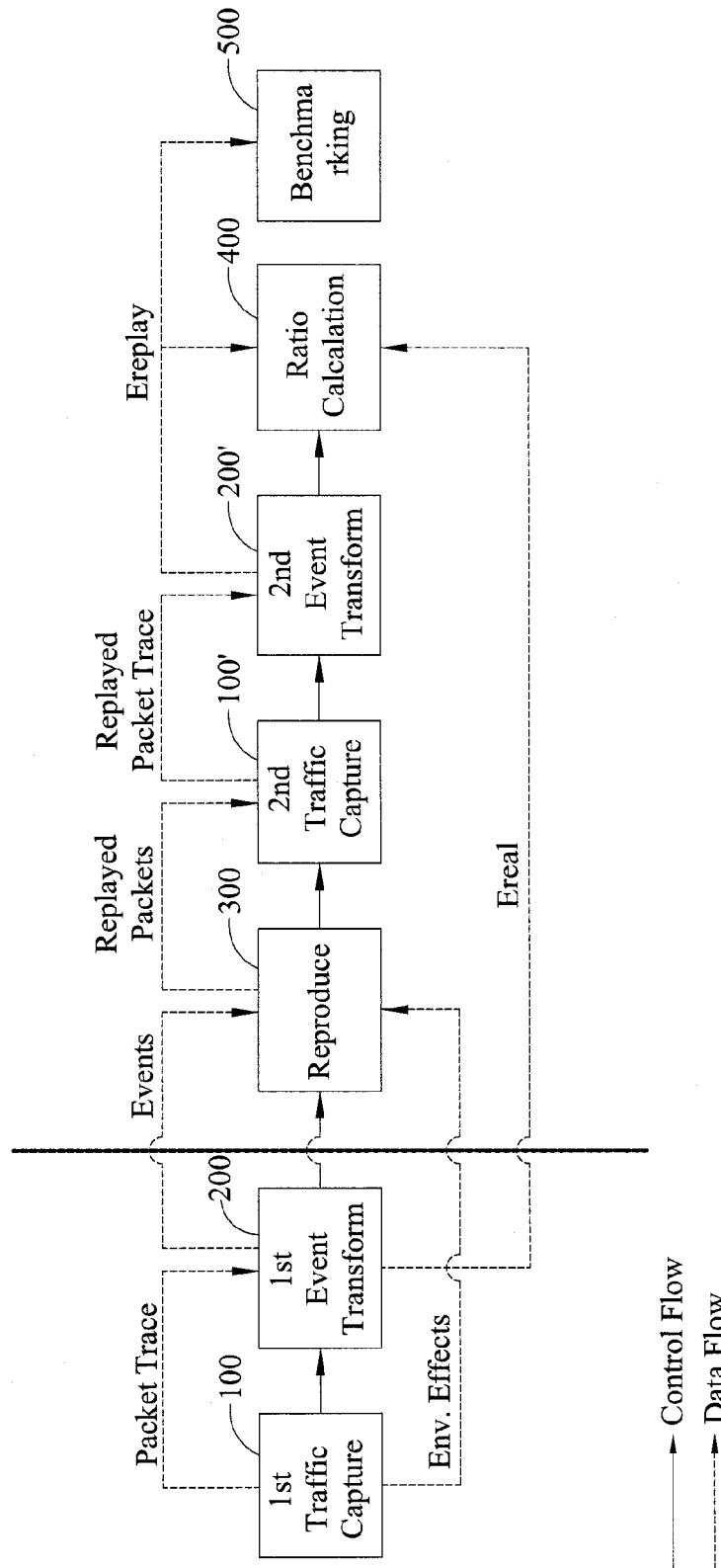

FIG. 2

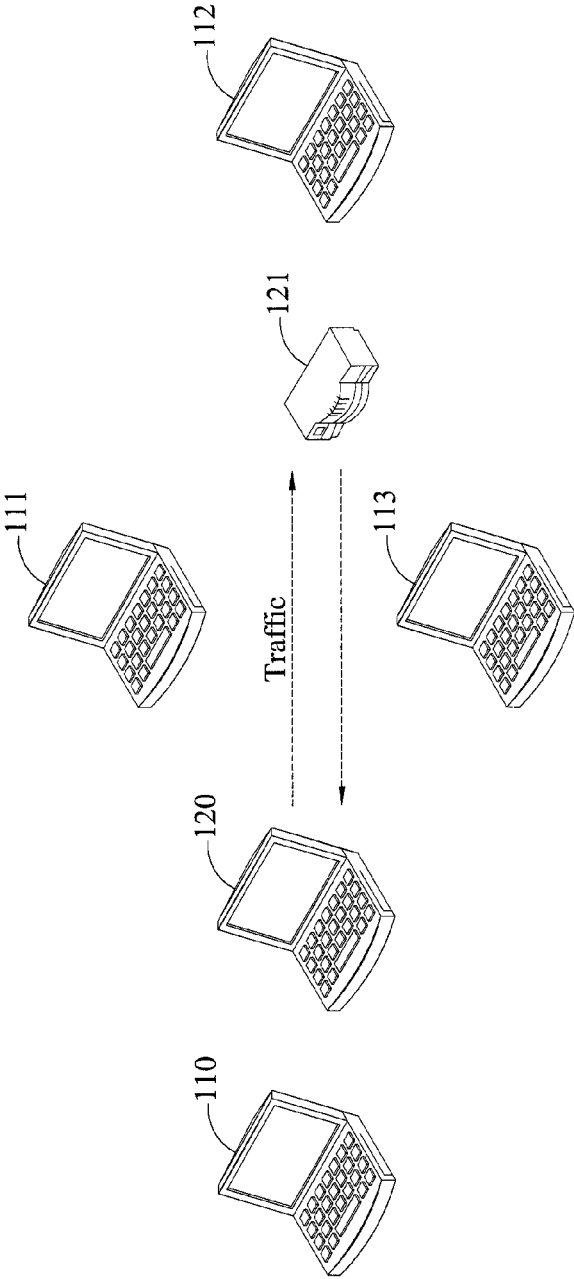

FIG. 3

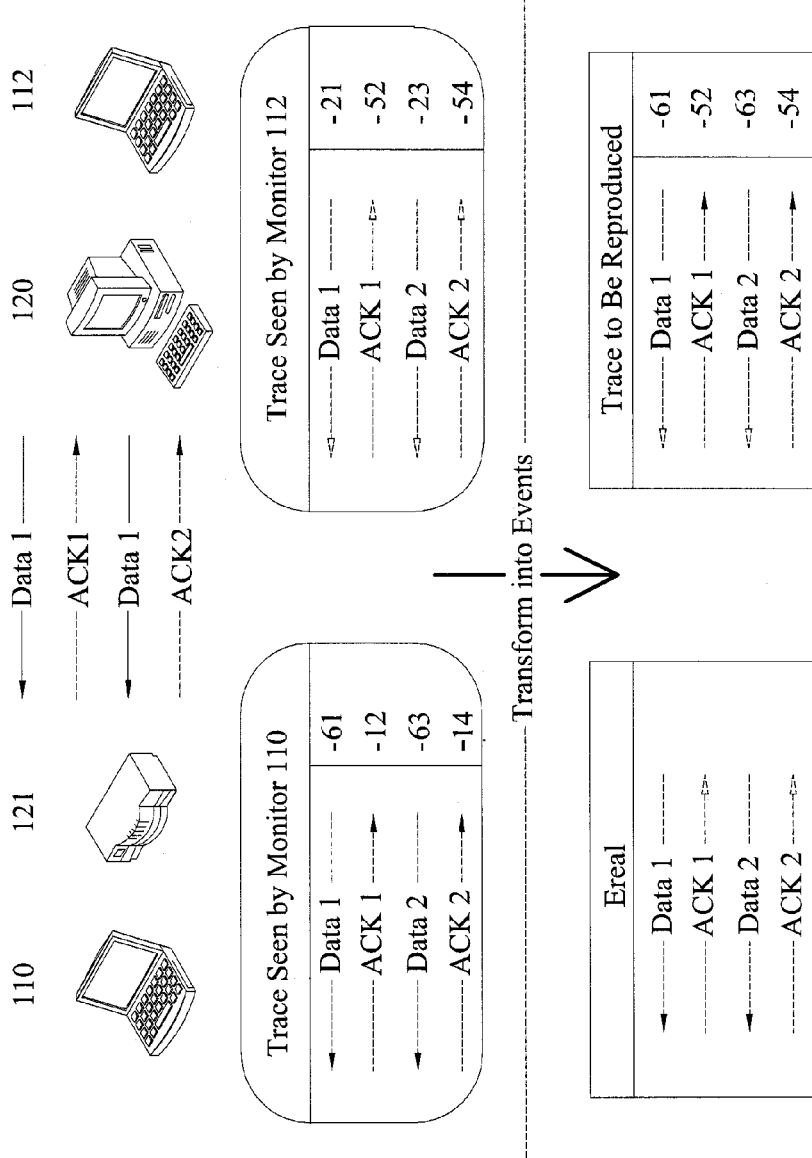

FIG. 4

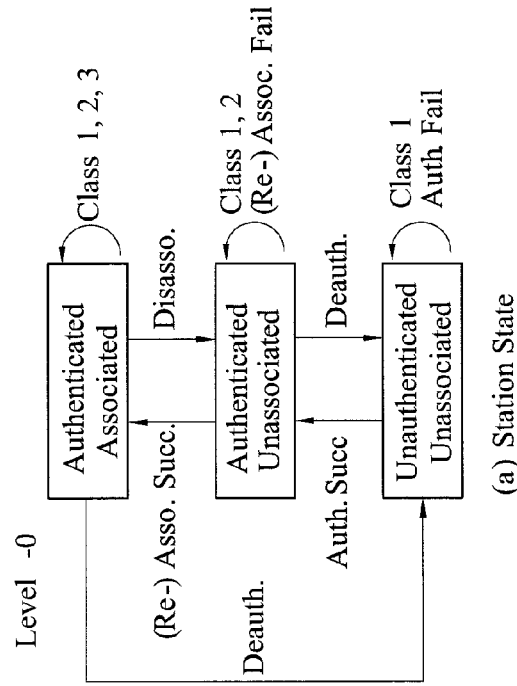

FIG. 5A

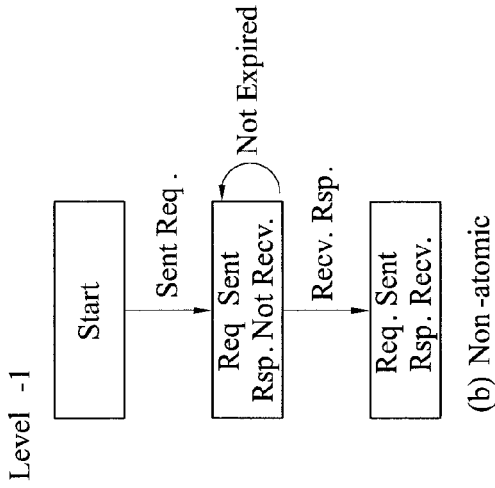

FIG. 5B

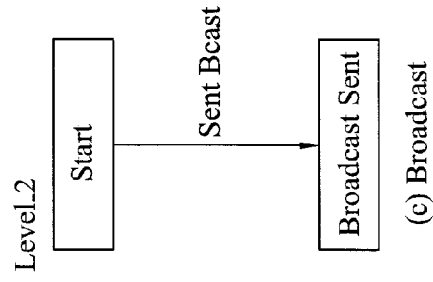

FIG. 5C

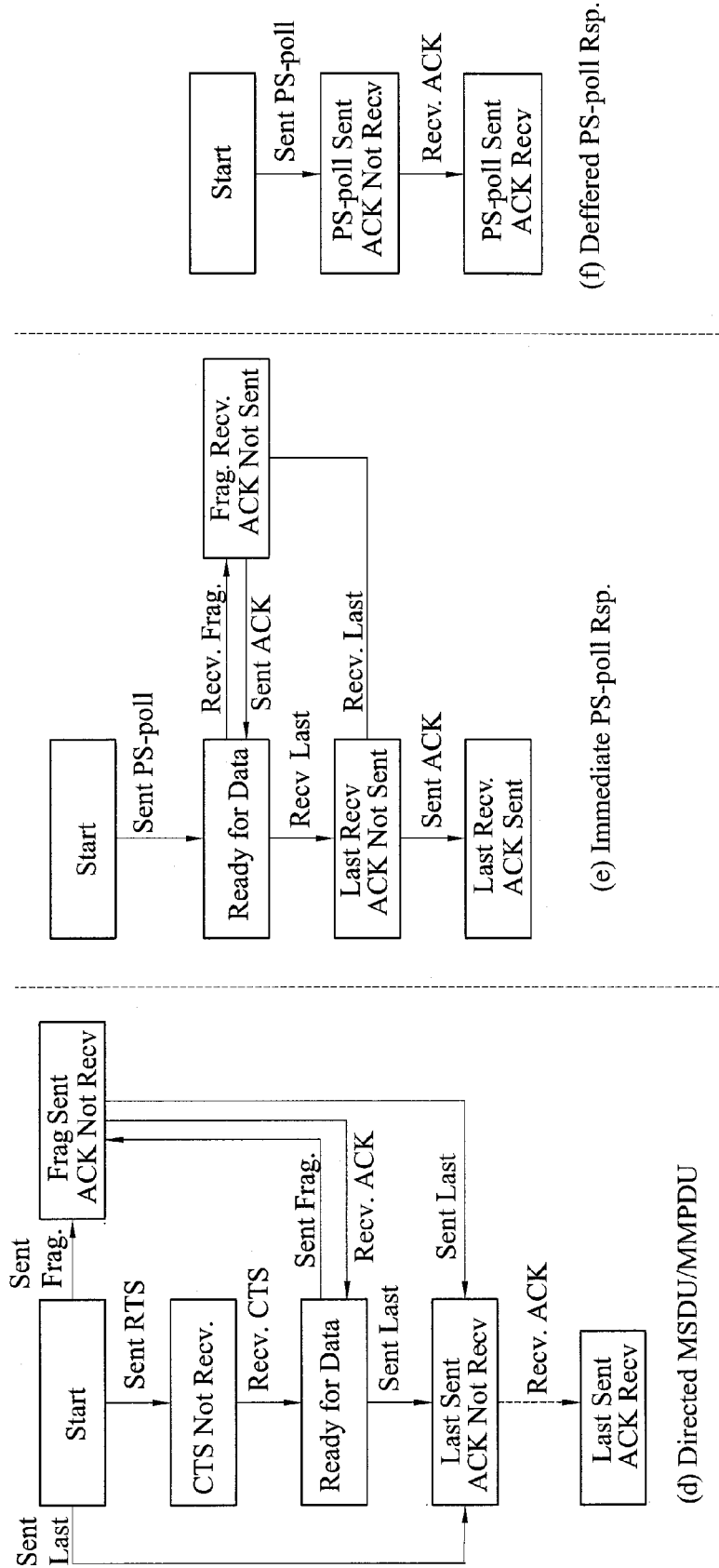

FIG. 5D

FIG. 5E

FIG. 5F

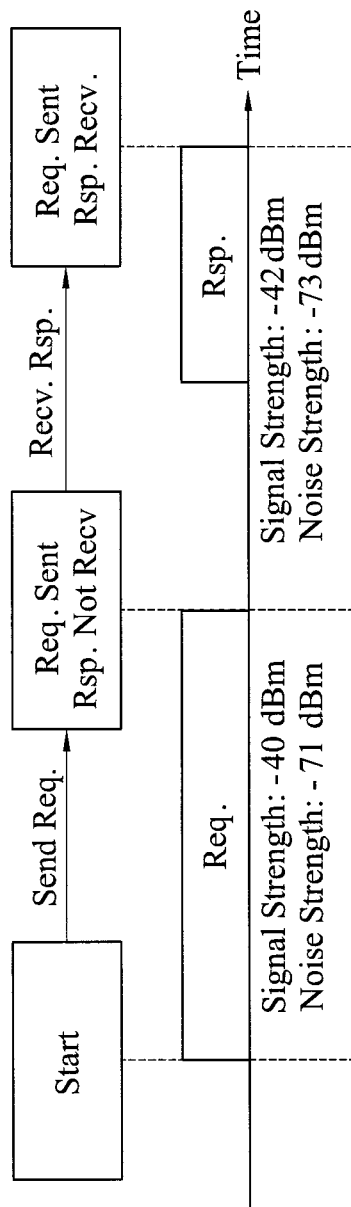

FIG. 6

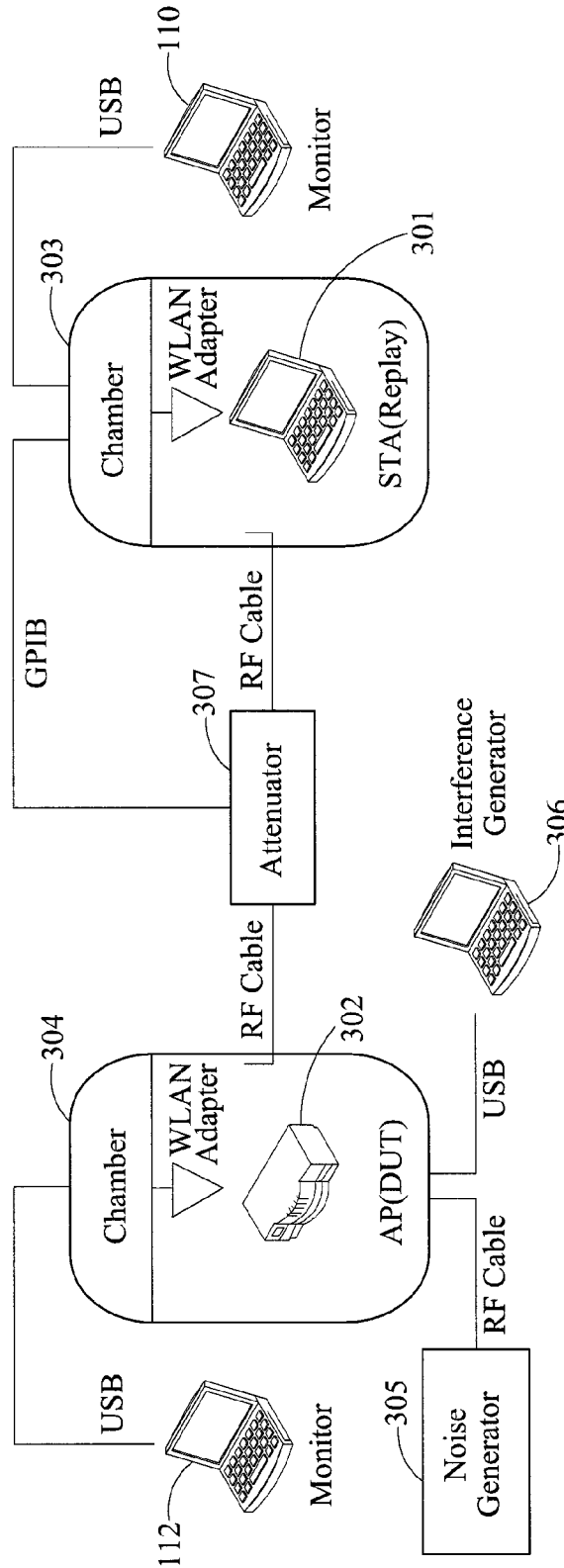

FIG. 7

SYSTEM FOR REAL TRAFFIC REPLAY OVER WIRELESS NETWORKS

BACKGROUND OF THE INVENTION

1. Field of the Invention

This invention relates to wireless local area networks (wireless networks), and, more particularly, to a system for real traffic replay over wireless networks.

2. Description of Related Art

Real traffic replay is highly applied in wired networks over the last decade. The packet exchanges with the device under test (DUT) should be precisely controlled following the protocol specification. However, traffic replay in wireless networks suffers further challenges due to variant wireless environments. Because a wireless medium is open and shared, transmissions may suffer packet errors caused by fading, noise, and interference. Therefore, traffic behaviors could be disturbed by environment effects. Even though the environment effects could be reproduced, poor coordination between the packet-replay control and environment emulation may result in inconsistent environment effects to packets. As a result, to apply real traffic replay in wireless networks requires not only packet-replay control but also environment emulation coordinately.

Compared to the packet traces record in the real environment, the reproduced traffic may suffer false negative (FN) and false positive (FP). FN indicates a successful packet exchange in the real environment fails in traffic replay. On the contrary, FP indicates a failed packet exchange in the real environment succeeds in traffic replay. Lack of packet-replay control, or environment emulation, or coordination between them may result in FN and FP cases.

In FIG. 1A, due to loss of packet-replay control, the ACK from Node A to Node B is transmitted in advance. The first and third Directed Data suffer FP and FN, respectively. Transmissions in wireless networks are prone to bit errors due to variant environments. In FIG. 1B, the first Directed Data intends to suffer FP because the noise disturbing the first Directed Data is not reproduced and the packet error rate decreases. In contrast, the second Directed Data encounters the unexpected noise due to lack of environment emulation. The FN case might occur. Even though the packet-replay control and environment emulation is applied, the poor coordination between them can also result in FN or FP cases. FIG. 1C shows that the reproduced noise with an uncontrolled duration could lead the second Directed Data to the FP case and the second Probe Req. to the FN case.

The above examples illustrate that lack of packet-replay control or environment emulation may highly affect the traffic behaviors. Therefore, both of the packet-replay control and environment emulation should be reproduced coordinately.

SUMMARY OF THE INVENTION

The present invention discloses a system for real traffic replay in wireless networks, the system comprises a first traffic capture module configured to capture packet traces and environment effects in a real environment and export the packet traces and environment effects; a first event transform module configured to receive the packet traces from the first traffic capture module and transform the packet traces into a sequence of events as well as export the sequence of events; and a reproduce module configured to receive the environment effects from the first traffic capture module and the sequence of events from the first event transform module such

as to control a replay of the environment effects in the real environment and the sequence of events coordinately by means of automata.

In addition, The system further comprises a second traffic capture module configured to capture a replayed packet traces from the reproduce module in a traffic replay environment and export the replayed packet traces; a second event transform module configured to receive the replayed packet traces from and the second traffic capture module and transform the replayed packet traces into a sequence of replayed events as well as export the sequence of replayed events; and a ratio calculation module configured to receive the sequence of events from the first event transform module and the sequence of replayed events from the second event transform module and compare thereof so as to calculate a reproduction ratio.

Moreover, the system further comprises a benchmarking module configured to provide the sequence of replayed events from the second event transform module for different devices under test to benchmark the acclimatization of the different device under test.

The first event transform module described above transforms the packet traces into the sequence of events following protocol, and the second event transform module described above transforms the replayed packet traces into the sequence of replayed events following the protocol. And in an embodiment, the first traffic capture module includes a plurality of monitors deposited in the real environment to record the packet traces between a station and an access point. The station and the access point play the role of a transmitter and a receiver in turn. The first traffic capture module determines weights of the monitors based on the signal amplitudes of packets received by the monitors, and determines whether the receiver has received the packets according to the weights of the monitors.

Consequently, the system for real traffic replay in wireless networks of this present invention defines a sequence of events following protocol (e.g. IEEE 802.11) to describe traffic behaviors, and applies automata to control a replay of the environment effects in the real environment and the sequence of events. Based on these events, this present invention defines the reproduction ratio to quantify the approximation level of the traffic replay environment to the real environment.

BRIEF DESCRIPTION OF THE DRAWINGS

The invention will be more readily understood in view of the following description when accompanied by the below figures, wherein like reference numerals represent like elements:

FIGS. 1A-1C are block diagrams of examples of false negative and false positive cases in real traffic replay;

FIG. 2 is a block diagram according to the present invention;

FIG. 3 is a block diagram of a multi-point device in a real environment according to an embodiment of the present invention;

FIG. 4 is a block diagram of an example of generating E_{Real} and traces to be reproduced;

FIGS. 5A-5F are block diagrams of a three level automata according to an embodiment of the present invention;

FIG. 6 is a block diagram of an example of synchronizing the environment effects; and

FIG. 7 is a block diagram of evaluation testbed according to an embodiment of the present invention.

DETAILED DESCRIPTION

Please refer to FIG. 2, which illustrates an embodiment of a system for real traffic replay in wireless networks. The

system comprises a first traffic capture module **100**, a first event transform module **200**, and a reproduce module **300**.

The first traffic capture module **100** may be configured to capture packet traces and environment effects in a real environment. The first traffic capture module **100** transmits the packet traces to the first event transform module **200** and transmits the environment effects to the reproduce module **300**.

The first event transform module **200** may be configured to receive the packet traces from the first traffic capture module **100** and transform the packet traces into a sequence of events. The first event transform module **200** transmits the sequence of events to the reproduce module **300**. The first event transform module **200** transforms the packet traces into the sequence of events following protocol (e.g., IEEE 802.11). Furthermore, the first event transform module **200** still transmits the sequence of events (Ereal) to a ratio calculation module **400** (to be described later).

The reproduce module **300** may be configured to receive the environment effects from the first traffic capture module **100** and the sequence of events from the first event transform module **200**.

Thus, the reproduce module **300** may integrate the environment effects and the sequence of events as well as control a replay of the environment effects by means of automata, wherein the reproduce module **300** replays the sequence of events transformed by the packet traces captured from a transmitter and replays the environment effect captured from a receiver in the real environment. The reproduce module **300** classifies the sequence of events by means of the automata prior to controlling the replay.

In an embodiment, the system may further comprise a second traffic capture module **100'**, a second event transform module **200'** and a ratio calculation module **400**.

The second traffic capture module **100'** may be configured to capture a replayed packet traces from the reproduce module **300** in a traffic replay environment. The second traffic capture module **100'** also transmits the replayed packet traces to the second event transform module.

The second event transform module **200'** may be configured to receive the replayed packet traces from the second traffic capture module **100'** and transform the replayed packet traces into a sequence of replayed events following protocol (e.g., IEEE 802.11). The second event transform module **200'** may also transmit the sequence of replayed events (Ereplay) to the ratio calculation module **400**. In addition, the second event transform module **200'** may transmit the Ereplay to a benchmarking module **500**.

The ratio calculation module **400** may be configured to receive the sequence of events from the first event transform module **200** and the sequence of replayed events from the second event transform module **200'**. The ratio calculation module **400** may compare the sequence of events and the sequence of replayed events so as to calculate a reproduction ratio to quantify the approximation level of the traffic replay environment to the real environment.

The benchmarking module **500** may be configured to provide the sequence of replayed events from the second event transform module **200'** for different UDTs to benchmark the performance of the different UDTs in an environment of the sequence of replayed events.

Refer to FIG. 3. The first traffic capture module **100** may employ the multi-node capture technology to capture packets in a real environment. The first traffic capture module **100** may include a plurality of monitors **110**, **111**, **112** and **113** deposited in the real environment to record the packet traces between a station **120** and an access point **121**. The station **120** and the access point **121** play the role of a transmitter and a receiver in turn. Weights of the plurality of monitors **110**, **111**, **112** and **113** can be determined based on the signal

amplitude of packet traces recorded by the plurality of monitors, and whether the receiver has received the packet traces can be determined according to the weights of the plurality of monitors **110**, **111**, **112** and **113**. In other words, a weight calculating method takes the weights of the monitors into consideration with respect to the same packet. For example, if the monitors **110**, **112**, **113** and **114** have weights equal to 0.2, 0.4, 0.2 and 0.2, respectively, and only the monitors **110**, **113** and **114** have recorded the packets, the receiver is determined to have received the packet since $0.2+0.2+0.2=0.6$, which is greater than or equal to 0.5.

Refer to FIG. 4, which illustrates an example of generating Ereal and packet traces to be reproduced.

Because of variant wireless environments, the packet traces and environment effects seen by the transmitter and receiver could be different. The transmitter-side cannot see the environment effect of each packet caused by the wireless channel. On the other hand, a portion of the receiver-side packets may be corrupted. Therefore, the reproduce module **300** reproduces the transmitter-side packets (i.e., replays the sequence of events transformed by the packet traces captured from the first traffic capture module **100**) with the receiver-side environment effects to the DUT (device under test). On the contrary, Ereal and Ereplay are extracted from the receiver-side packets. Considering bidirectional transmissions, a station (STA) **120** and an access point (AP) **121** play the role of transmitter and receiver in turn.

Ereal can be extracted from the receiver-side packets that are composed of the black left arrows at monitor **110** and white right arrows at the monitor **112**. On the other hand, the packet traces to be reproduced consists of the transmitter-side packets and receiver-side environment effects. Note that the transmitter-side packets consist of the black right arrows at monitor **110** and white left arrows at the monitor **112**. The receiver-side environment effects are -52 and -54 dBm for the black right arrows, and -61 and -63 dBm for the white left arrows, respectively.

The automata are shown in FIGS. 5A to 5F. The reproduce module **300** may classify the sequence of events by means of the automata, and then integrate the environment effects from the first traffic capture module **100** and the sequence of events from the first event transform module **200** coordinately by means of the automata, and further control a replay of the environment effects in the real environment and the sequence of events coordinately by means of automata. And to keep correct interactions with the DUT, the reproduce module **300** applies the three-level automata, such as level-0, level-1 and level-2, to control the replay, wherein the level-1 automaton deals with events that allow an interruption between a request and a response, and the level-2 automaton deals with events that do not allow an interruption between a request and a response.

FIG. 5A depicts the level-0 automaton that maintains the station states for a STA **120** and exists at both the STA **120** and AP **121**. The valid packets in each state are classified into Class 1, 2, and 3 according to the Authentication and Association statuses. To make all the reproduced packets acceptable to the DUT (refers to AP **121** herein), the reproduce module **300** keeps the same station state as the state in the real environment. If unexpected behaviors of the DUT triggered state transition, the reproduce module **300** would apply the Authentication or Association procedure to transit to a correct state. For example, when the DUT send a De-authentication or a Disassociation, the reproduce module **300** is aware of the change of station states. Then the reproduce module **300** would originate an Authentication or Association procedure to the DUT to return to the original state.

The level-2 automata address the atomic events that should not be interrupted by the other events. Atomic events can be mapped to the basic operation sequence defined in IEEE

802.11. The state transitions of the level-2 automata are triggered by only packet exchanges. In FIG. 5, except the Broadcast automaton that does not interact with the DUT, the other level-2 automata should transmit a captured packet after the previous packet has been received from the DUT. The Directed MSDU or MMPDU automaton addresses the unicast data or management frames. The Immediate PS-poll Rsp. and Deferred PS-poll Rsp. automata handle retrieving the buffered data during the power-saving mode. Note that Frag. denotes a fragment of data whereas Last indicates the last fragment of data.

The level-1 automaton deals with non-atomic events that allow other events occur between the request and response. The state transitions of the level-1 automata are triggered by atomic events. For example, after sending the Association Request, the reproduce module 300 also allows redundant Probe Requests and Responses before receiving the Association Response from the DUT. The association procedure still completes. Table 1 summarizes the relationship among the automata and events.

TABLE 1

RELATIONSHIP BETWEEN EVENTS AND THREE-LEVEL AUTOMATA		
Level	Automata	Event
0	Station state	Station state
1	Non-atomic	Auth. Assoc. Re-assoc.
2	Broadcast	Active Scan Broadcast Data Broadcast Probe Req. Beacon Interference
	Directed MSDU/MMPDU	Unicast Data Unicast Probe Req./Probe Rsp. Auth. Req./Auth. Rsp. Assoc. Req./Assoc. Rsp. Re-assoc. Req./Re-assoc. Rsp. De-auth. Disassoc.
	Immediate PS-poll Rsp. Deferred PS-poll Rsp.	Immediate PS-poll Deferred PS-poll

When the reproduce module 300 reproduces the captured packets from the first traffic capture module 100, the corresponding environment effects should also be generated. Because the real environment affects the error probability of each packet, each reproduce packet and the environment effect it suffers should be synchronized. Thus, the reproduce module 300 synchronizes the reproduced packets and environment effects by the level-2 automata. Since the transitions

of the level-2 automata are triggered by packet exchanges, the reproduce module 300 adjusts the environment factors at each state transition.

In wireless communications, several environment factors, such as fading, noise, and interference, may increase the bit error rate. Fading represents that the signal strength of transmitted packets decreases due to path loss or shadowing. Noise is a random disturbance signal that cannot be recognized by the wireless communication system. Interference is originated by other devices that intend to access the shared medium in the same wireless communication system. To emulate the key environment factors, the reproduce module 300 uses an attenuator to adjust the signal strength according to RSSI, and a vector signal generator to generate the noise by AWGN according to the record noise strength. Because the packets collided with each other would be considered as noise, the reproduce module 300 emulate the interference by reproducing only the captured packets that are irrelative to the DUT without packet-replay control. That is, interference is treated as a special event controlled by the Broadcast automaton.

Here illustrates an example of synchronizing the environment effects with the packet-replay control in FIG. 6.

Refer to FIG. 6. When the system intends to transmit the Req. to the DUT, the signal and noise strength is set to -40 and -71 dBm, respectively. After sending the Req., the reproduce module 300 immediately sets the signal and noise strength to -42 and -73 dBm, respectively, until the DUT replies the Rsp.

The experiments as FIG. 7 illustrated examine the packet-replay control and environment emulation separately. Moreover, a case study is provided to observe the relationships of reproduction ratios and upper-layer cases.

The testbed consists of two chambers 303 and 304 to separate the uncontrollable open environment. An AP 302 plays the role of the DUT and an STA 301 plays the role of the replay are put in the chambers, respectively. To capture the traffic at both the transmitter and receiver sides, two monitors 110 and 112 capture the packets and environment effects by the WLAN adapters through the USB interface. For environment emulation, an attenuator 307 that adjusts the signal strength connects to both of the chambers 303 and 304 through RF cables. At the DUT side, a noise generator 305 and an interference generator 306 generate the noise and interference, respectively. We put all the devices at the fixed positions and calibrate them carefully before the experiments.

After evaluating the reproduction ratio, the following experiments intend to investigate the relationships between the link-layer events and the upper-layer cases. Table 2 summarizes the experimental results.

TABLE 2

CASE STUDY OF UPPER-LAYER CASES							
	Link	ICMP	UDP (TFTP)		UDP (TFTP) in clean env.		TCP
			in dirty env.		BMP	MP3	
association	(Ping)	BMP file	MP3 file	file	file	(Telnet)	
Reproduction ratio	100%	99.42%	98.08%	99.70%	99.89%	99.14%	58.11%
Test case succ. ratio	100%	86.99%	0% (13.3% Transmitted)	0% (0.96% Transmitted)	99.87%	82.23%	0% (12% Transmitted)

These experiments investigate the network-layer (ICMP) and transport-layer (UDP and TCP) cases, and compare the results with the reproduction ratios of the link layer. For the link layer, because the link-layer behaviors can be handled by the reproduced module 300 immediately, the reproduction ratio is consistent with the success ratio of link association. For the ICMP, the reproduction ratio is slightly higher than the number of successful Ping because a portion of Ping fails in the real environment due to the corrupted Ping Responses from the DUT.

For the UDP, the experiment intends to send a BMP file (300 KB) and a MP3 file (2 MB) by the TFTP. The reproduction ratio is near 100% but no file can be successfully sent. The reason is that the captured traffic in the real environment is incomplete. A portion of packets might be lost. When the system reproduces the TFTP packets with a gap of sequence number, the TFTP server requests the TFTP client to retransmit the lost packet and does not merge the contents of the following packets. Another experiment operates in a clean environment and all the packets are captured correctly. In this case, most of the reproduced TFTP transmissions are complete. Therefore, defects of capture highly affect the effectiveness of traffic replay.

For the TCP, the Telnet connection establishment is applied in this experiment. The result shows the low reproduction ratio and no successful Telnet connection establishment. A TCP connection establishment requires the three-way handshake to negotiate the ACK and sequence numbers. However, the reproduced ACK and sequence numbers are inconsistent in the new negotiation. The TCP connection cannot be established and the following packets would also be rejected. Thus, the subsequent events fail due to the Telnet server does not generate the subsequent packets appeared in the real environment. As a result, upper-layer protocols may degrade reproduction ratios because the actions of the DUT may be determined by upper-layer protocols.

Therefore, the contents of a packet have to be adjusted according to the variations of the upper layers, or the upper layer protocols will not be established successfully and the replay result is affected. Thus, the reproduce module 300 may replay the sequence of events from the first event transform module 200 and the environment effects from the first traffic capture module 100 according to the variations of the upper layer (e.g., a network layer, a transport layer, and an application layer) protocols. Table 3 lists parameters affecting the upper layer protocols. The parameters are determined according to the protocols. In other words, different protocols adopt different parameters according to their specification definitions.

Table 3 takes TCP as an example, in which Destination IP Address, Source IP Address, Destination Port Number, Source Port Number, Sequence Number, Ack. Number, Checksum, Window Size and the like are employed. It is known that the parameters may affect whether the upper layer protocols can be established successfully. Table 3 lists examples for the attributes. The attributes are defined according to test conditions and environment, and can be modified statically or dynamically. The attributes include a static modification and a dynamic modification. The static modification indicates that the parameters are determined before replaying process (the replaying process means that the reproduce module replays the sequence of events from the first event transform module and the environment effects from the first traffic capture module), and can be processed in an early stage, which is recommended. On the contrary, the dynamic modification indicates that values or contents have to be changed in

time in response to any change of the upper layer protocols during the replaying process, which introduces overloads additionally.

TABLE 3

parameters affecting the upper layer protocols and attributes changing the parameters	
parameter (variable)	Destination IP Address, Source IP Address, Destination Port Number, Source Port Number, Sequence Number, Ack. Number, , Checksum, Windows Size, etc.
attribute (attribute)	Static Modification, Dynamic Modification, Dynamic Response, etc.

Taking TCP protocol as an example, three attributes that the parameters may have are Static Modification, Dynamic Modification, and Dynamic Response. The Static Modification attribute that indicates the corresponding information can be aware in packet traces. The corresponding information can be corrected by parsing the packet trace and modifying according to the configuration of the test bed. Destination IP Address, Source IP Address, Destination Port Number, and Source Port Number belong to this category. The Dynamic Modification attribute that indicates the corresponding information cannot be aware in packet traces. The corresponding information needs to be modified according to the response from the DUT. Sequence Number, Ack. Number, and Checksum belong to this category. When the Initial Send Sequence is originated by the DUT, A reproduce module should replay a Sequence Number equal to the Initial Send Sequence plus one. The Dynamic Response attribute indicates that the corresponding information should be issued according to the grant of the DUT. Window Size belongs to this category. A reproduce module should be aware of whether the size of the next packet satisfies the limitation of Window Size.

This invention provides a real traffic replay solution with environment emulation to reproduce traffic behaviors of IEEE 802.11 in the real environment. The present invention defines a series of events following the IEEE 802.11 protocol. The present invention uses the three-level automata to achieve the packet-replay control and synchronizes the environment effect with each packet. A performance metric called production ratio is defined to quantify the result of traffic replay. The packet traces in the real environment and traffic replay environment are transformed into Ereal and Ereplay, respectively. Finally, calculates the reproduction ratio.

What is claimed is:

1. A system for real traffic replay in wireless networks, comprising:
 - a first traffic capture module configured to capture packet traces and environment effects in a real environment and export the packet traces and the environment effects, wherein the first traffic capture module includes a plurality of monitors disposed in the real environment to record the packet traces;
 - a first event transform module configured to receive the packet traces from the first traffic capture module, transform the packet traces into a sequence of events, and export the sequence of events;
 - a reproduce module configured to receive the environment effects from the first traffic capture module and the sequence of events from the first event transform module so as to control a replay of the environment effects in the real environment with the sequence of events coordinately by means of automata; and
 - a ratio calculation module configured to receive the sequence of events from the first event transform module

9

- and compare the sequence of events and a sequence of replayed events so as to calculate a reproduction ratio.
2. The system as recited in claim 1, further comprising:
 a second traffic capture module configured to capture a replayed packet traces from the reproduce module in a traffic replay environment and export the replayed packet traces; and
 a second event transform module configured to receive the replayed packet traces from the second traffic capture module, transform the replayed packet traces into the sequence of replayed events, and export the sequence of replayed events.
3. The system as recited in claim 2, further comprising a benchmarking module configured to provide the sequence of replayed events from the second event transform module for different devices under test to benchmark the performance of the different devices under test.
4. The system as recited in claim 2, wherein the first event transform module transforms the packet traces into the sequence of events following a protocol, and the second event transform module transforms the replayed packet traces into the sequence of replayed events following the protocol.
5. The system as recited in claim 1, wherein the record the packet traces between a station and an access point.
6. The system as recited in claim 5, wherein the station and the access point play the role of a transmitter and a receiver in turn.
7. The system as recited in claim 6, wherein the first traffic capture module determines weights of the plurality of monitors based on signal amplitudes of packet traces recorded by the plurality of monitors, and determines whether the receiver has received the packet traces according to the weights of the plurality of monitors.
8. The system as recited in claim 6, wherein the reproduce module replays the sequence of events transformed by the packet traces captured from the transmitter and by the environment effect captured from the receiver.

10

9. The system as recited in claim 5, wherein the automat has three levels, the level-0 automaton maintains the station state for the station, the level-1 automaton deals with events that allow an interruption between a request and a response, and the level-2 automaton deals with events that do not allow an interruption between a request and a response.
10. The system as recited in claim 1, wherein the reproduce module classifies the sequence of events by means of the automata prior to controlling the replay.
11. The system as recited in claim 1, wherein the reproduce module replays the sequence of events from the first event transform module and the environment effects from the first traffic capture module according to variations of upper layer protocols.
12. The system as recited in claim 11, wherein the upper layer protocols include a network layer protocol, a transport layer protocol, and an application layer protocol.
13. The system as recited in claim 11, wherein the upper layer protocols are affected by parameters, and the parameters are determined according to the upper layer protocols.
14. The system as recited in claim 13, wherein the parameters have attributes including a static modification.
15. The system as recited in claim 13, wherein the parameters have attributes including a dynamic modification.
16. The system as recited in claim 14, wherein the static modification indicates that the parameters are determined prior to the reproduce module's replaying the sequence of events from the first event transform module and the environment effects from the first traffic capture module.
17. The system as recited in claim 15, wherein the dynamic modification indicates that contents of the attributes have to be changed in time in response to any change of the upper layer protocols while the reproduce module replays the sequence of events from the first event transform module and the environment effects from the first traffic capture module.

* * * * *